

HIFONICS®
C A R A U D I O
POWER FROM THE GODS

HFXR

**2/3-WAY CROSSOVER WITH
REMOTE CONTROL**

Thank you for purchasing the Hifonics HFXR 2 / 3-Way crossover. This model operates as either a 2 or 3-way crossover with an 18dB /Octave subwoofer crossover with remote gain control module. This unit will provide filtered signals to front and rear amplifiers, and Low Pass subwoofer output using a single pair of inputs. Please read the entire manual to ensure proper connections and application.

FEATURES

BASS BOOST WITH QUASI-PARAMETRIC EQUALIZATION

A sealed enclosure causes the woofers frequency response to roll off at a rate is 12dB per Octave below the enclosures resonant frequency. Our Bass Boost Quasi-Parametric Equalization circuitry provides a single Octave boost at 12dB at 45Hz to ensure smooth and accurate bass response

DC / DC REGULATED SWITCHING POWER SUPPLY

This power supply design provides constant voltage regardless of the battery's voltage to ensure constant output performance at all times

FREQUENCY MULTIPLIER

The front High Pass section is equipped with a frequency multiplier switch that can be used to multiply the crossover frequency points. With the additional selectable crossover points, system settings become precise

REAR INPUT SWITCH

Using this switch, a rear signal output can be delivered from a single input source with out having to use an adaptor to split the input cables

FRONT/REAR INPUTS WITH FRONT/REAR/SUB OUTPUTS

This unit has front and rear pre-amp inputs with front and rear outputs as well as a constant subwoofer output that is independent of the fader position on the source unit

ADJUSTABLE OUTPUT LEVEL CONTROL

STEREO / MONO SUBWOOFER CONTROL SWITCH

REMOTE LEVEL CONTROL VIA UNDER-DASH MODULE

Maxxsonics Limited Warranty

As the manufacturer of Maxxsonics, Autotek, MB Quart, Crunch and Hifonics car audio products, Maxxsonics USA Inc. Warrants to the original consumer purchaser the amplifier to be free from defects in material and workmanship for one (1) Year from date of purchase.

All other parts and accessories of the system are warrantied to be free from defects in material and workmanship for one (1) year from date of purchase. Maxxsonics will repair or replace at it's option and free of charge during the warranty period, any system component that proves defective in materials and workmanship under normal installation, use and service provided that the product is returned to the authorized Maxxsonics dealer from where it was purchased. A photo copy of the original receipt must accompany the product being returned.

Valid purchase receipts will contain the name and address of the authorized reseller.

Any damage to the product as a result of misuse, abuse, accident, incorrect wiring, improper installation, alteration of date code or bar code labels, revolution, natural disaster, or any sneaky stuff because someone messed up, repair or alteration out side of our factory or authorized service centers and any thing else you have done that you should not have done is not covered.

This warranty is limited to defective parts and specifically excludes any incidental or consequential damages connected therewith. This warranty is not to be construed as an insurance policy.

Warranty on installation labor, removal, re-installation and freight charges are not the responsibility of Maxxsonics USA Inc.

Warranty products damaged as a result of insufficient or improper packing materials are not covered by this limited warranty and such damaged product will be returned as is at the expense of the owner.



MAXXSONICS
Designed and Engineered in the USA
www.maxxsonics.com

FEATURE DESCRIPTIONS

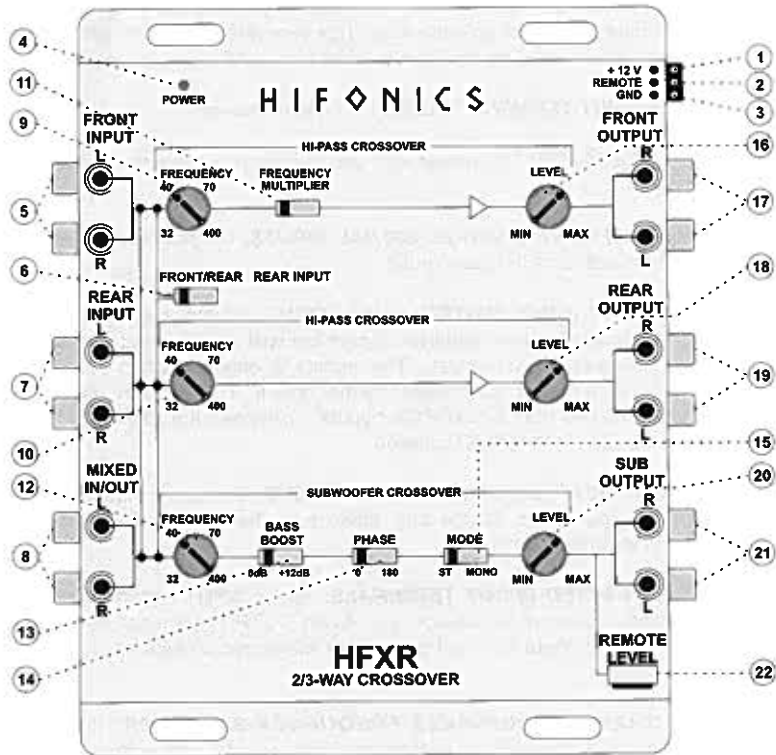

FEATURE DESCRIPTIONS

- 1. POWER INPUT TERMINAL:** Connect to the battery + positive terminal with 5 amp in-line fuse
- 2. REMOTE TURN-ON TERMINAL:** Connect to the source unit (radio/CD player) remote turn-on or antenna wire. This wire should get +12 volts when the source unit is turned on and 0 volts when turned off.
- 3. GROUND INPUT TERMINAL:** Connect to chassis ground
- 4. POWER INDICATOR:** The power light will illuminate green when the unit is turned on
- 5. LEFT/RIGHT FRONT CHANNEL SIGNAL INPUTS:** Connect to the Front (L & R) channel output of the source unit.
- 6. FRONT / REAR INPUT SWITCH:** In the FRONT position, the input signals coming in through the front channel signals are split and directed to the front and rear channels simultaneously. This feature is engaged when the source unit has no front/rear or subwoofer channel output. In the REAR position, if the source unit has front & rear RCA outputs, disengage the REAR inputs by placing the switch in the REAR position
- 7. LEFT/RIGHT REAR CHANNEL SIGNAL INPUTS:** Connect to the rear (L & R) channel output of the source unit. Make sure that the REAR INPUT switch is in the REAR position
- 8. LEFT/RIGHT MIXED IN/OUT TERMINALS:** As an INPUT terminal, connect the subwoofer output of the source unit. As an OUTPUT terminal, connect to the front channel input terminal of another electronic crossover in a multi-crossover system
- 9. FRONT CHANNEL HIGH-PASS FREQUENCY SELECTOR:** In the x1 position, the high-pass crossover frequency range is adjustable from 32Hz to 400Hz and in the x20 position, the frequency range is adjustable from 640Hz to 8KHz. This allows for fine tuning
- 10. REAR CHANNEL HIGH-PASS FREQUENCY SELECTOR:** Allows selection of REAR channel High-Pass frequency from 32Hz to 400Hz

11. **FRONT CHANNEL HIGH-PASS FREQUENCY MULTIPLIER:** In the x1(times one) position, the Front High-Pass frequency is adjustable from 32Hz to 400Hz and in the x20(times twenty) the frequency is adjustable from 640Hz to 8KHz
12. **SUBWOOFER FREQUENCY SELECTOR:** Adjustment of the Low-Pass crossover frequency for the subwoofer channel from 32Hz to 400Hz
13. **BASS BOOST SWITCH:** When activated, this circuit provides a single Octave boost of 12dB at 45Hz to equalize the sub enclosure
14. **PHASE INVERTER:** In the "180" position, the unit shifts the sub output signal 180 degrees out of phase relative to the front and rear output signals
15. **SUBWOOFER STEREO / MONO SWITCH:** Selects stereo or mono for the subwoofer output
16. **FRONT CHANNEL OUTPUT LEVEL CONTROL:** Allows for adjustment of the front channel output signal
17. **LEFT/RIGHT FRONT CHANNEL OUTPUT TERMINALS:** Connect to the amplifier front channel left/right inputs
18. **REAR CHANNEL OUTPUT LEVEL CONTROL:** Allows for adjustment of the rear channel output signal level
19. **LEFT/RIGHT REAR CHANNEL OUTPUT TERMINALS:** Connect to the amplifier rear channel left/right inputs
20. **SUBWOOFER OUTPUT LEVEL CONTROL:** Allows for adjustment of the subwoofer channel output signal level
21. **LEFT/RIGHT SUBWOOFER OUTPUT TERMINALS:** Connect to the amplifier subwoofer or non-fading output
22. **REMOTE LEVEL CONTROL:** This is the under-dash mounted bass remote module which adjusts the Low-Pass level.

CHANNEL SOURCE UNIT

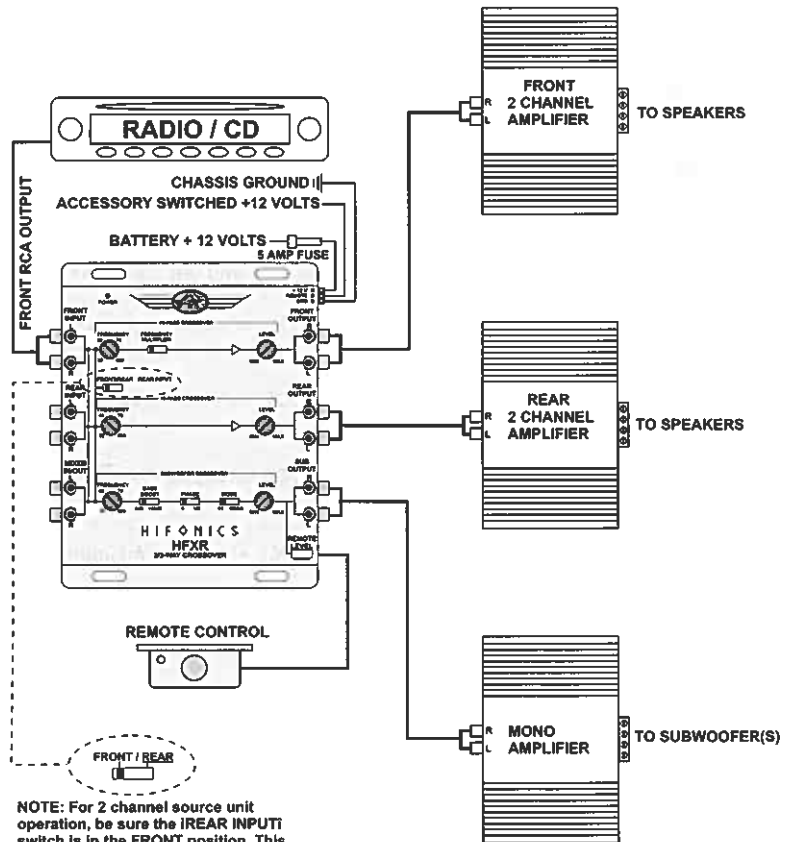

NOTE: For 2 channel source unit operation, be sure the **IREAR INPUT** switch is in the **FRONT** position. This will direct the audio input signal to both front and rear outputs

CHANNEL SOURCE UNIT

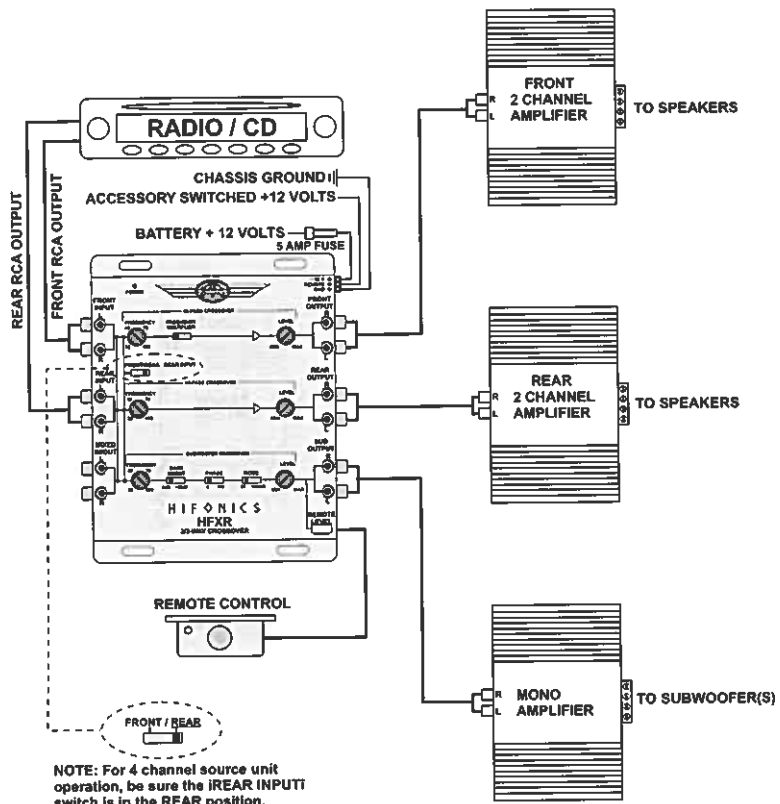

CHANNEL SOURCE UNIT

